



Designation: D365 – 23

# Standard Guide for Soluble Nitrocellulose Base Solutions<sup>1</sup>

This standard is issued under the fixed designation D365; the number immediately following the designation indicates the year of original adoption or, in the case of revision, the year of last revision. A number in parentheses indicates the year of last reapproval. A superscript epsilon ( $\epsilon$ ) indicates an editorial change since the last revision or reapproval.

## 1. Scope

1.1 This guide covers the testing of soluble nitrocellulose base solutions that are made by dispersing various kinds and concentrations of soluble nitrocellulose (cellulose nitrate) in various solvent mixtures.

1.2 The values stated in SI units are to be regarded as the standard. The values given in parentheses are for information only.

1.3 *This standard does not purport to address all of the safety concerns, if any, associated with its use. It is the responsibility of the user of this standard to establish appropriate safety, health, and environmental practices and determine the applicability of regulatory limitations prior to use.* For specific hazard statements see Section 11.

1.4 *This international standard was developed in accordance with internationally recognized principles on standardization established in the Decision on Principles for the Development of International Standards, Guides and Recommendations issued by the World Trade Organization Technical Barriers to Trade (TBT) Committee.*

## 2. Referenced Documents

2.1 *ASTM Standards:*<sup>2</sup>

D333 Guide for Clear and Pigmented Lacquers

<sup>1</sup> This guide is under the jurisdiction of ASTM Committee D01 on Paint and Related Coatings, Materials, and Applications and is the direct responsibility of Subcommittee D01.55 on Factory Applied Coatings on Preformed Products.

Current edition approved June 1, 2023. Published June 2023. Originally approved in 1933. Last previous edition approved in 2017 as D365 – 01 (2017). DOI: 10.1520/D0365-23.

<sup>2</sup> For referenced ASTM standards, visit the ASTM website, [www.astm.org](http://www.astm.org), or contact ASTM Customer Service at [service@astm.org](mailto:service@astm.org). For *Annual Book of ASTM Standards* volume information, refer to the standard's Document Summary page on the ASTM website.

D1193 Specification for Reagent Water

D1200 Test Method for Viscosity by Ford Viscosity Cup

E300 Practice for Sampling Industrial Chemicals

## 3. Significance and Use

3.1 Since the desired specifications and compositions of soluble nitrocellulose base solutions vary greatly, these methods are used to establish whether limits that shall be as agreed upon between the producer and the user have been met.

## 4. Sampling

4.1 Select the sampling method from those listed in Practice E300.

## CONSISTENCY (VISCOSITY)

## 5. Consistency Tests

5.1 *For Consistencies Less than 3 s*—Determine the consistency by Test Method D1200 for those solutions having a consistency of less than 3 s when tested in the falling-ball apparatus referred to in Section 6.

5.2 *For Consistencies over 3 s*—Determine the consistency using the apparatus and procedure described in Sections 6 and 7 for those solutions having a consistency greater than 500 s when tested in the falling-ball apparatus referred to in Section 6.

## 6. Apparatus

6.1 The consistency test apparatus, shown in Fig. 1, shall consist of the following:

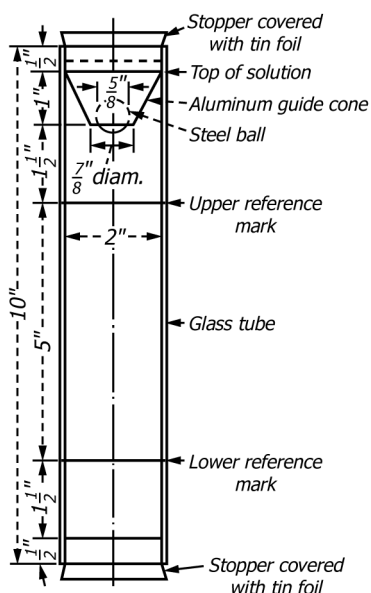

**FIG. 1 Apparatus for Consistency (Viscosity) Test of Solutions Having Consistencies over 500 s**

6.1.1 *Glass Tube* (preferably heat-resistant glass),<sup>3</sup> 50 mm  $\pm$  1.5 mm (2 in.  $\pm$  1/32 in.) in inside diameter and 255 mm (10 in.) in length, with marks 177 mm  $\pm$  1 mm (5 in.  $\pm$  1/16 in.) apart, the upper one being 75 mm (3 in.) from the top of the tube.

NOTE 1—The steel ball can be removed (in order to leave the same material in the tube for a check run) by removing the lower stopper. However, a small air bubble is usually introduced in this way. It is preferable to invert the tube, removing the guide to get the ball out. It is often necessary to put a few drops of solvent in the guide lip to loosen it from the tube on account of the solution drying at the edge of the tube. When the latter method is used for removing the ball, a larger bubble traverses the tube than when the former method is used, but a large bubble moves sufficiently fast, even in a very viscous solution, to escape at the top in a few minutes, whereas small bubbles take hours to escape.

6.1.2 *Steel Ball*, 15.88 mm  $\pm$  0.02 mm (0.625 in.  $\pm$  0.001 in.) in diameter, and weighing 16.536 g  $\pm$  0.10 g.

6.1.3 *Aluminum Guide Cone* of light gauge aluminum (approximately 0.5 mm (0.02 in.) in thickness) as shown in Fig. 1. The orifice of the guide cone shall be 22 mm (7/8 in.) in diameter, the conical portion 25 mm (1 in.) in height, the cylindrical portion 12.7 mm (1/2 in.) in height, and the outside diameter shall be slightly under 50 mm (2 in.) so as to fit snugly into the viscosity tube.

6.1.4 *Stoppers*, made preferably of rubber and covered with tin foil.

## 7. Procedure

7.1 Fill the tube in any convenient manner whereby bubbles do not form and no appreciable amount of solvent is lost. One method is to immerse the lower end of the open tube in the solution and to apply suction at the upper end of the tube. In this manner the tube can be filled in from 5 s to 10 s without the introduction of air bubbles or an appreciable loss of solvent.

Close the bottom of the tube with a stopper covered with tin foil. Push the aluminum guide cone slowly into the top of the tube and insert a stopper covered with tin foil into the top of the guide.

7.2 Bring the tube and its contents to a temperature of 25 °C  $\pm$  0.1 °C by placing in a suitable bath. Allow at least 30 min for the solution to reach temperature equilibrium. For accurate measurements keep the tube during the determination either in a thermostat or suspended within a considerably larger cylinder of water at the specified temperature.

7.3 Remove the upper stopper only long enough to place the ball in the center of the tube; this can be done conveniently with crucible tongs. The principal value of the guide cone is to retard the ball sufficiently at the start of its fall so that the solution will close over the ball and not leave on the top of the ball a large “trailer bubble.” If the guide is not used a big trailer bubble usually accompanies the ball, retarding its fall and, if the bubble is off center on the ball, pulling the latter away from the center of the tube.

7.4 Measure the time of fall in seconds from the instant the bottom of the ball is level with the upper reference mark on the tube until it reaches the lower mark on the tube.

## NONVOLATILE MATTER

### 8. Procedure

8.1 Determine the percent of nonvolatile matter in accordance with the procedure described in the Nonvolatile Matter section of Test Methods D333.

## APPEARANCE OF SOLUTION

### 9. Procedure

9.1 Compare the appearance of the soluble nitrocellulose base solution with a reference standard agreed upon between the purchaser and the seller (both the reference standard and sample solutions shall be thoroughly agitated before making observations) in similar bottles for turbidity, hair, grain, and insoluble matter.

## DEPTH OF COLOR

### 10. Apparatus

10.1 The apparatus used for the preparation of the color standards and for the depth of color determinations shall consist of the following:

10.1.1 *Light*—Source of transmitted light.

NOTE 2—Not absolutely necessary but will increase accuracy and be more convenient.

10.1.2 *Bottles*, three dozen 60 mL (2 oz L) screw-cap, square, glass.

10.1.3 *Flasks*, several, 1 L, volumetric.

10.1.4 *Burets*, two, 50 mL.

10.1.5 *Analytical Balance*.

10.1.6 *Colorimeter*—Dubosq colorimeter (see Note 2).

<sup>3</sup> Borosilicate glass is satisfactory for this purpose.